

OmniRidge® PRO Shingle Over Ridge Vent

INSTALLATION INSTRUCTIONS

Thank you for your purchase of the OmniRidge® Pro Shingle Over Ridge Vent. The OmniRidge® Pro Shingle Over Ridge Vent is an exhaust vent that will help rid your attic of damaging heat and moisture when properly installed and used in conjunction with intake vents located near the lower part of the attic space.

NOTE: Most codes concerning residential attic ventilation require a balanced system of 50% exhaust ventilation and 50% intake ventilation. When this balanced system is used, the TopShield® OmniRidge® Pro Vent will meet or exceed residential attic ventilation codes.

IMPORTANT Read ALL instructions thoroughly before attempting to install the OmniRidge® Pro Shingle Over Ridge Vent.

OmniRoll® Vent Installation

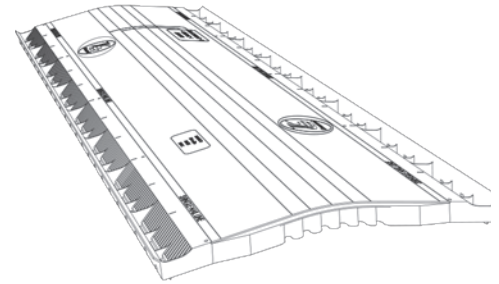

LIMITED LIFETIME WARRANTY
See manufacturer or distributor for details.

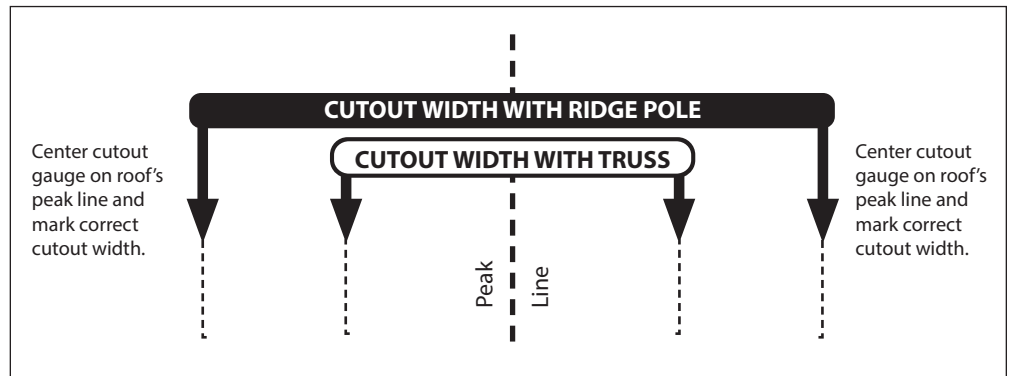
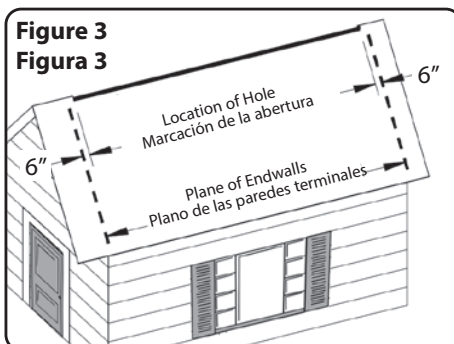
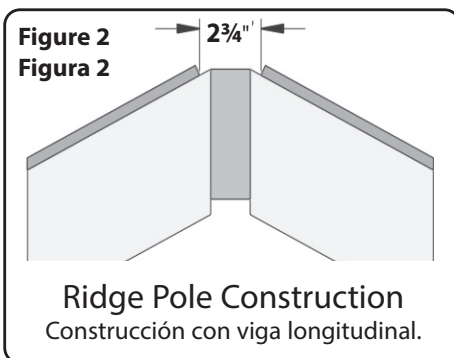
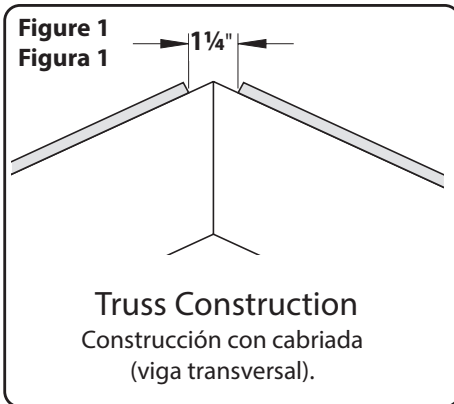

STEP 1 — The OmniRidge® Pro Vent will look better if it extends the entire length of the roof and therefore blends in with the roof line. Measure the length of the roof peak to determine the total length of OmniRidge® Pro Vent one will need.

NOTE: DO NOT CUT THE HOLE THE ENTIRE LENGTH OF THE RIDGE. THE LENGTH OF THE CUT WILL BE ONE (1) FOOT LESS THAN THE LENGTH BETWEEN THE END WALLS (SEE STEP 3).

STEP 2 — Remove the cap shingles the entire length of the ridge if the house already has shingles. Do not install cap shingles on new construction.

STEP 3 — The width of the cut will depend on whether your home is built with "Truss Construction" (1." wide cut) or "Ridge Pole Construction" (3." wide cut). If you are not sure, look into the attic and compare the ridge construction to Figures 1 and 2.

The length of the cut should end 6 inches inside each end wall as shown in Figure 3. Mark the width to be cut with a chalk line (for a straighter cut) and also mark the end of the cuts. The hole is best cut with a circular saw taking care to set the depth of the cut to avoid cutting any rafters. Cut the hole and remove the cut decking.

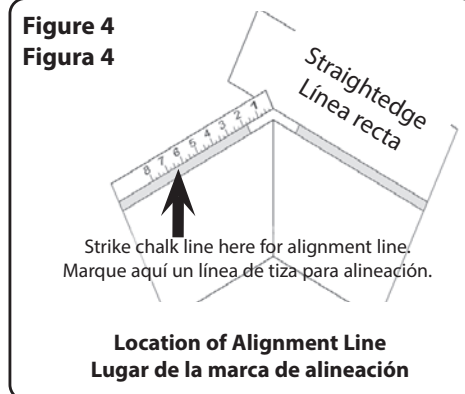

STEP 4 — It is very important that the OmniRidge® Pro Vent be aligned correctly and evenly down the roof's ridge. Snap a chalk line down both sides of the ridge at a distance of 7" down from the peak as shown in Figure 4. The chalk lines should be used to help keep the OmniRidge. Pro centered over the peak of the roof.

Scan the QR code to access additional information



OmniRidge® PRO Shingle Over Ridge Vent

INSTALLATION INSTRUCTIONS

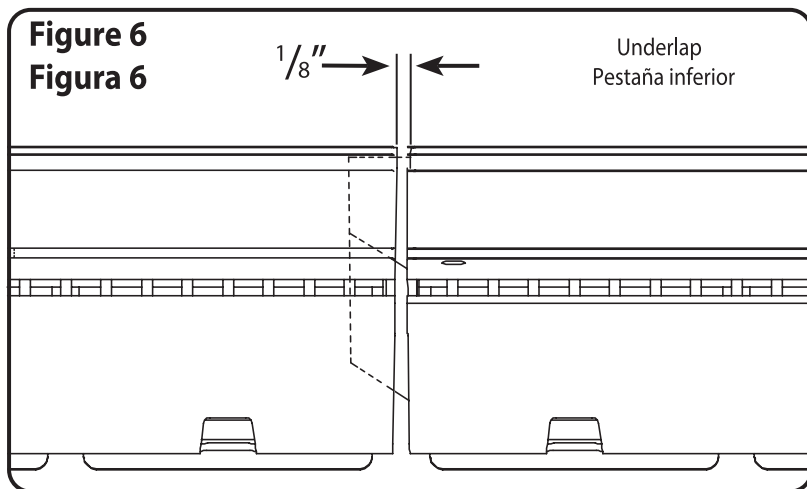
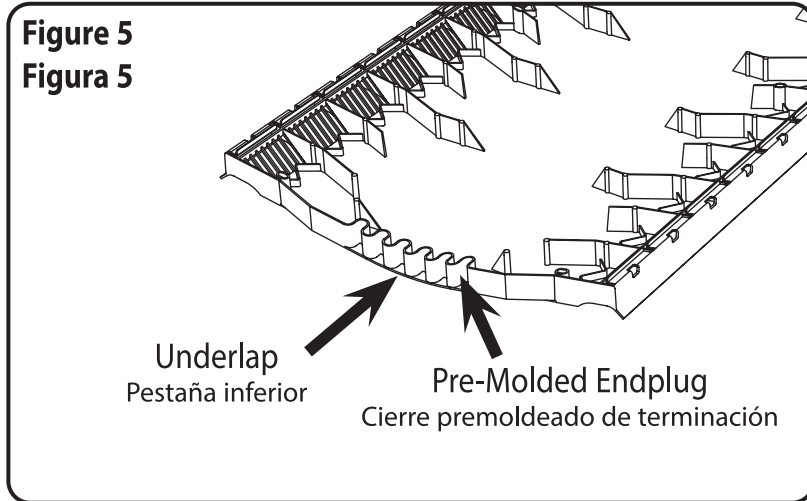

STEP 5 — Additional end plugs are not necessary because of the unique, pre-molded internal end plugs. The OmniRidge® Pro Vent is made with alignment tabs at each end. One end has a 3/8" long underlap (Fig. 5) and the other end is recessed to receive the underlap. Place the first piece flush with the end of the roof. Continue to mate the ends together for the entire length of the ridge, this will help to ensure that all of the vents are as straight as possible. Orient the part so the 3/8" underlap is pointed in the direction of install. This will allow for an easier install.

STEP 6 — Supported nail holes are provided approximately every foot. Starting with the first vent, nail the OmniRidge® Pro Vent in place. Do not nail one complete side down at once. Instead, use the two nail holes at the end of the vent first, then the next two holes, and so on as you continue down the vent. Nails should be a minimum of 2" long. Continue the installation, mating each end together and leaving a 1/8" expansion gap on each underlap as shown in Fig. 6. This allows for expansion in hot weather. Continue to nail the remaining pieces down taking care to keep the vents as straight as possible. The last piece may have to be cut to the proper length, a utility knife should work well. The vent is marked every 4" for recommended cut line. Be sure that the end plug is on the outside end of the last piece if the piece was cut.

STEP 7 — Install new cap shingles on top of the OmniRidge. Pro Vent. Use nails of sufficient length to ensure they penetrate a minimum of 3/4" into or through the roof decking. A nail line has been provided on the top of each vent to assist you.

3 MUST DO STEPS TO ATTIC VENTILATION

- 1** **Install all Exhaust Ventilation at the SAME HEIGHT within a common attic area.**
Installation of exhaust vents at more than one level on a roof allows the upper exhaust vent to pull air in from lower exhaust vents rather than from the intake vents. Intake air must come from intake vents located near the lower part of the attic space to properly ventilate the total attic area and eliminate weather infiltration.
- 2** **Install ONLY ONE TYPE of Exhaust Ventilation within a common attic area.**
Exhaust Vents pull air from the easiest intake source. Vent types cannot be mixed. The use of different types of exhaust vents could make one of the vents act as intake for the other. Intake air must come from intake vents located near the lower part of the attic space to properly ventilate the total attic area and eliminate weather infiltration.
- 3** **Install a BALANCED SYSTEM of Intake and Exhaust Ventilation.**
50% Intake Ventilation - Intake vents located near the lower part of the attic area are required to balance out your ventilation system.
50% Exhaust Ventilation - Exhaust vents located near the upper part of the attic area are required to balance out your ventilation system.

Scan the QR code
to access additional
information

